

30V Dual N-Channel Enhancement Mode MOSFET

Description

The PECN4842SR uses advanced trench technology to provide excellent $R_{DS(ON)}$ with low gate charge.

This device is suitable for high side switch in SMPS and general purpose applications.

General Features

- ◆ $V_{DS} = 30V, I_D = 10A$
 $R_{DS(ON)} = 20m\Omega$ (typical) @ $V_{GS} = 10V$
 $R_{DS(ON)} = 28m\Omega$ (typical) @ $V_{GS} = 4.5V$
- ◆ Excellent gate charge x $R_{DS(ON)}$ product(FOM)
- ◆ Very low on-resistance $R_{DS(ON)}$
- ◆ 150 °C operating temperature
- ◆ Pb-free lead plating
- ◆ 100% UIS tested

Application

- ◆ DC/DC Converter
- ◆ Ideal for high-frequency switching and synchronous rectification

Package

- ◆ SOP-8

100% UIS TESTED!
100% ΔV_{ds} TESTED!

Schematic diagram

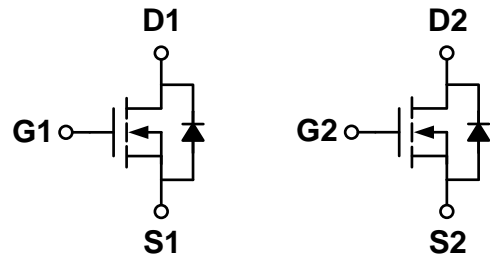

Marking and pin assignment

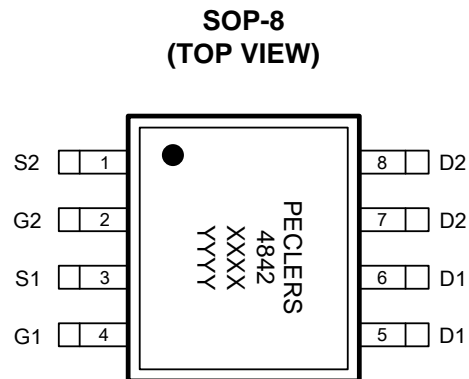

Note:

XXXX is the date code ,
 YYYY is the Quality Code r.



Ordering Information

Part Number	Storage Temperature	Package	Devices Per Reel
PECN4842SR	-55°C to +150°C	SOP-8	4000

Absolute Maximum Ratings (TA=25°C unless otherwise noted)

parameter	symbol	limit	unit	
Drain-source voltage	V_{DS}	30	V	
Gate-source voltage	V_{GS}	±20	V	
Drain Current-Continuous (Silicon Limited)	I_D	$T_A = 25^\circ C$	8	A
		$T_A = 75^\circ C$	6.5	
Pulsed Drain Current (Package Limited)	I_{DM}	40	A	
Single pulse avalanche energy	E_{AS}	10	mJ	
Maximum power dissipation	P_D	$T_A = 25^\circ C$	2	W
		$T_A = 75^\circ C$	1.3	

Operating junction Temperature range	T _j	-55—150	°C
--------------------------------------	----------------	---------	----

Electrical Characteristics (TA=25°C unless otherwise noted)

Parameter	Symbol	Condition	Min	Typ	Max	Unit
OFF Characteristics						
Drain-source breakdown voltage	BV _{DSS}	V _{GS} =0V, I _D =250μA	30	-	-	V
Zero gate voltage drain current	I _{DSS}	V _{DS} =30V, V _{GS} =0V	-	-	1	μA
Gate-body leakage	I _{GSS}	V _{DS} =0V, V _{GS} =±20V	-	-	±100	nA
ON Characteristics						
Gate threshold voltage	V _{GS(th)}	V _{DS} =V _{GS} , I _D =250μA	1.0	1.55	3.0	V
Drain-source on-state resistance	R _{DS(ON)}	V _{GS} =10V, I _D =8A	-	20	25	mΩ
		V _{GS} =4.5V, I _D =6A	-	28	35	
Forward transconductance	g _{fs}	V _{DS} =5V, I _D =8A	-	20	-	S
Dynamic Characteristics						
Input capacitance	C _{ISS}	V _{DS} =15V, V _{GS} =0V f=1.0MHz	-	373	448	pF
Output capacitance	C _{OSS}		-	67	-	
Reverse transfer capacitance	C _{RSS}		-	41	-	
Gate resistance	R _g	V _{GS} =0V, V _{DS} =0V, f=1.0MHz	-	1.8	2.8	Ω
Switching Characteristics						
Turn-on delay time	t _{D(ON)}	V _{DS} =15V V _{GS} =10V R _L =1.5Ω R _{GEN} =3Ω	-	4.5	11	ns
Rise time	t _r		-	2.7	-	
Turn-off delay time	t _{D(OFF)}		-	14.9	-	
Fall time	t _f		-	2.9	-	
Total gate charge	Q _g	V _{DS} =15V, I _D =10A V _{GS} =10V	-	7.2	11	nC
Gate-source charge	Q _{gs}		-	1.3	-	
Gate-drain charge	Q _{gd}		-	1.7	-	

Thermal Characteristics

Parameter	Symbol	Typ	Max	Unit
Maximum Junction-to-Ambient ^A	R _{θJA}	33	40	°C/W
Maximum Junction-to-Ambient ^A		Steady-State	59	
Maximum Junction-to-Lead ^B	R _{θJC}	16	24	

A: The value of R_{θJA} is measured with the device mounted on 1 in² FR-4 board with 2oz. Copper, in a still air environment with T_A=25°C. The value in any given application depends on the user's specific board design. The current rating is based on the t ≤ 10s thermal resistance rating.

B: The R_{θJA} is the sum of the thermal impedance from junction to lead R_{θJC} and lead to ambient.

Test Circuit:

(1)、EAS Test Circuit

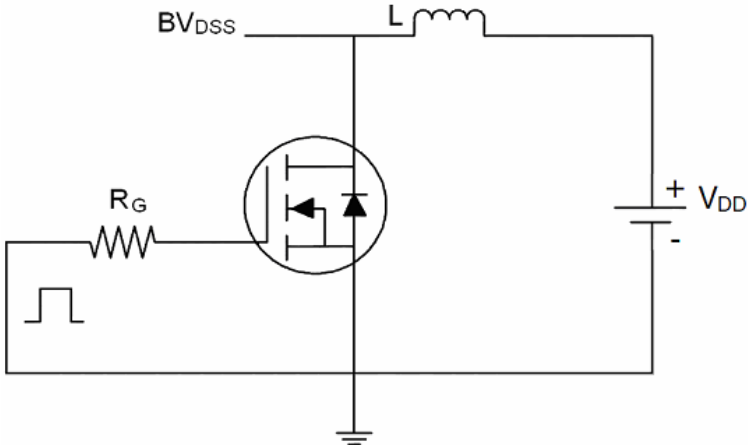

(2)、Gate Charge Test Circuit

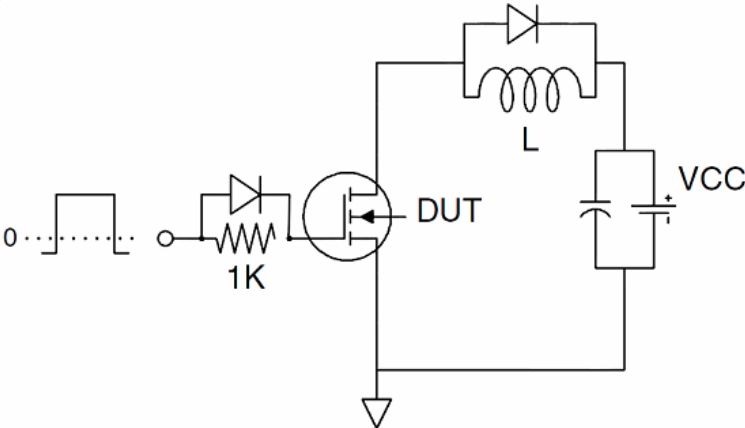

(3)、Switch Time Test Circuit

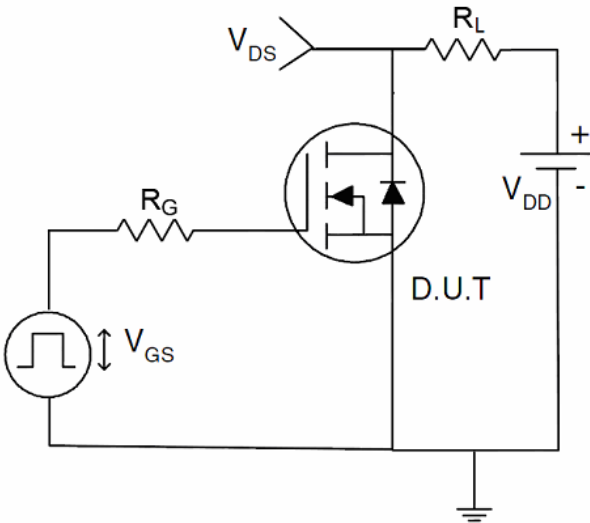

Package Information

- SOP-8

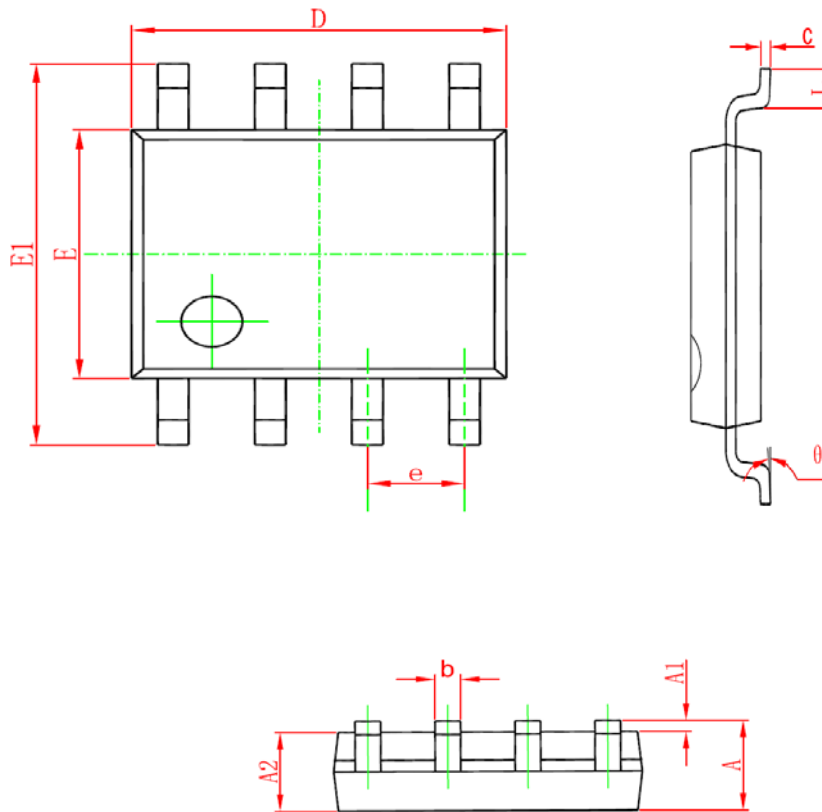

Symbol	Dimensions In Millimeters		Dimensions In Inches	
	Min	Max	Min	Max
A	1.350	1.750	0.053	0.069
A1	0.100	0.250	0.004	0.010
A2	1.350	1.550	0.053	0.061
b	0.330	0.510	0.013	0.020
c	0.170	0.250	0.006	0.010
D	4.700	5.100	0.185	0.200
E	3.800	4.000	0.150	0.157
E1	5.800	6.200	0.228	0.244
e	1.270 (BSC)		0.050 (BSC)	
L	0.400	1.270	0.016	0.050
θ	0°	8°	0°	8°

Recommended Minimum Pads

- SOP-8

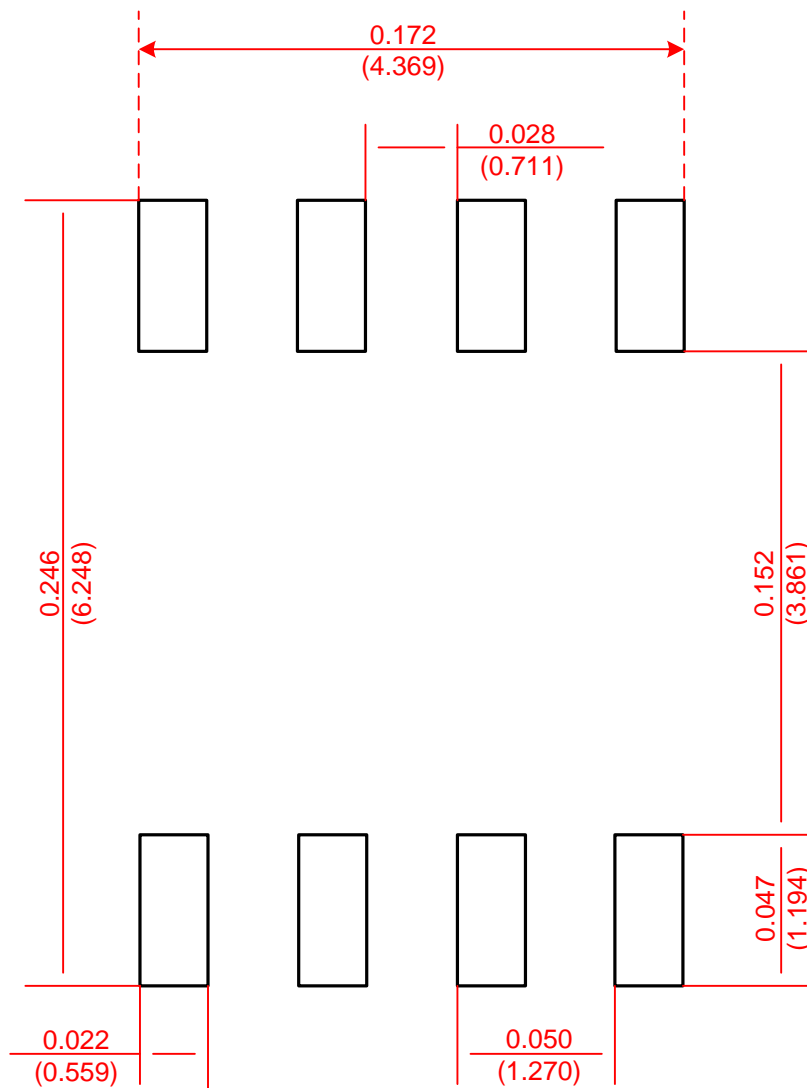

Recommended Minimum Pads
Dimensions in Inches/(mm)

● SOP-8

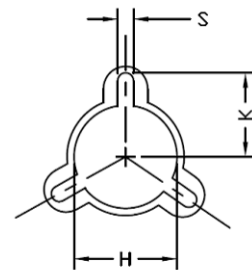
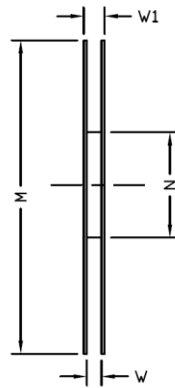
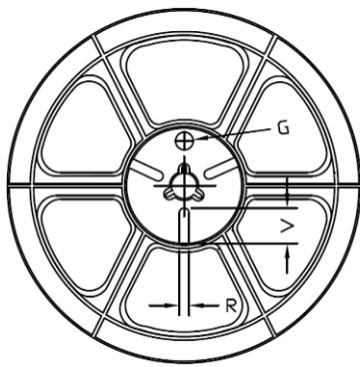
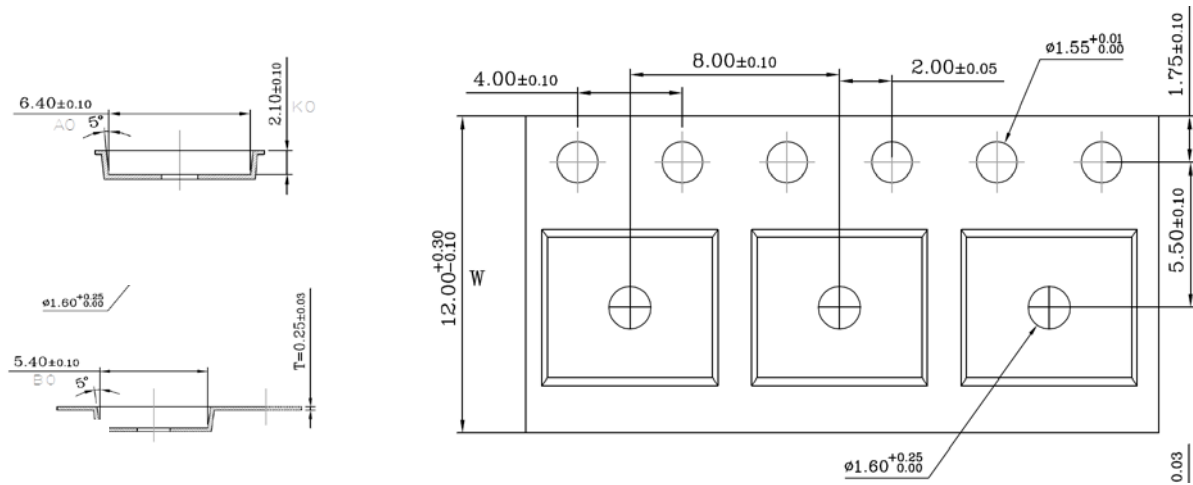

Tape Size	Reel Size	M	N	W	W1	H	K	S	G	R	V
12mm	Φ330	Φ330.00 ±0.50	Φ97.00 ±0.30	13.00 ±0.30	17.40 ±1.00	Φ13.00 ±0.5	10.6	2.00 ±0.50	—	—	—

Unit Per Reel:
4000pcs

