

60V Dual N-Channel Enhancement Mode MOSFET

Description

The PECN4826SR uses advanced trench technology to provide excellent $R_{DS(ON)}$ with low gate charge.

This device is suitable for high side switch in SMPS and general purpose applications.

General Features

- ◆ $V_{DS}=60V, I_D=6A$
 $R_{DS(ON)}=19m\Omega$ (typical) @ $V_{GS}=10V$
 $R_{DS(ON)}=22m\Omega$ (typical) @ $V_{GS}=4.5V$
- ◆ Excellent gate charge x $R_{DS(ON)}$ product(FOM)
- ◆ Very low on-resistance $R_{DS(ON)}$
- ◆ 150 °C operating temperature
- ◆ Pb-free lead plating

Application

- ◆ DC/DC Converter
- ◆ Ideal for high-frequency switching and synchronous rectification

Package

- ◆ SOP-8

100% UIS TESTED!

100% ΔV_{ds} TESTED!

Schematic diagram

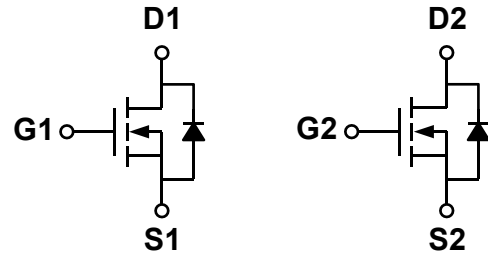

Marking and pin assignment

SOP-8
(TOP VIEW)

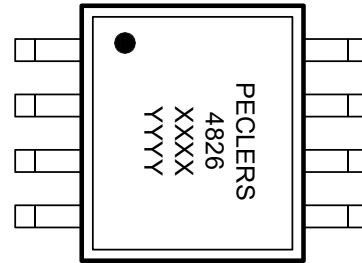

Note:

XXXX is the Wafer Information

YYYY is the Quality Code



Ordering Information

Part Number	Storage Temperature	Package	Devices Per Reel
PECN4826SR	-55°C to +150°C	SOP-8	4000

Absolute Maximum Ratings (TA=25°C unless otherwise noted)

parameter	symbol	limit	unit	
Drain-source voltage	V_{DS}	60	V	
Gate-source voltage	V_{GS}	±20	V	
Drain Current-Continuous (Silicon Limited)	I_D	$T_A=25^\circ C$	6	A
		$T_A=75^\circ C$	4	
Pulsed Drain Current (Package Limited)	I_{DM}	24	A	
Single pulse avalanche energy(L=0.5mH)	E_{AS}	80	mJ	
Maximum power dissipation	P_D	$T_A=25^\circ C$	2	W
		$T_A=75^\circ C$	1.3	
Operating junction Temperature range	T_j	-55—150	°C	

Electrical Characteristics (TA=25°C unless otherwise noted)

Parameter	Symbol	Condition	Min	Typ	Max	Unit
OFF Characteristics						
Drain-source breakdown voltage	BV_{DSS}	$V_{GS}=0V, I_D=250\mu A$	60	-	-	V
Zero gate voltage drain current	I_{DSS}	$V_{DS}=60V, V_{GS}=0V$	-	-	1	μA
Gate-body leakage	I_{GSS}	$V_{DS}=0V, V_{GS}=\pm 20V$	-	-	± 100	nA
ON Characteristics						
Gate threshold voltage	$V_{GS(th)}$	$V_{DS}=V_{GS}, I_D=250\mu A$	1.2	1.9	2.5	V
Drain-source on-state resistance	$R_{DS(on)}$	$V_{GS}=10V, I_D=6A$	-	19	25	m Ω
		$V_{GS}=4.5V, I_D=4A$	-	22	28	
Forward transconductance	g_{fs}	$V_{DS}=5V, I_D=6A$	-	28	-	S
Dynamic Characteristics						
Input capacitance	C_{ISS}	$V_{DS}=30V, V_{GS}=0V$ $f=1.0MHz$	-	1900	2250	pF
Output capacitance	C_{OSS}		-	150	-	
Reverse transfer capacitance	C_{RSS}		-	115	-	
Gate resistance	R_g	$V_{GS}=0V, V_{DS}=0V,$ $f=1.0MHz$	-	5	8	Ω
Switching Characteristics						
Turn-on delay time	$t_{D(ON)}$	$V_{DS}=30V$ $V_{GS}=10V$ $R_L=1.5\Omega$ $R_{GEN}=3\Omega$	-	7.5	-	ns
Rise time	t_r		-	5	-	
Turn-off delay time	$t_{D(OFF)}$		-	28	-	
Fall time	t_f		-	5.5	-	
Total gate charge	Q_g	$V_{DS}=30V, I_D=6A$ $V_{GS}=10V$	-	46	-	nC
Gate-source charge	Q_{gs}		-	6	-	
Gate-drain charge	Q_{gd}		-	14.2	-	

Thermal Characteristics

Parameter	Symbol	Typ	Max	Unit
Maximum Junction-to-Ambient ^A	$\leq 10s$	33	40	°C/W
Maximum Junction-to-Ambient ^A	Steady-State			
Maximum Junction-to-Lead ^B	Steady-State	$R_{\theta JC}$	16	

A: The value of $R_{\theta JA}$ is measured with the device mounted on 1 in² FR-4 board with 2oz. Copper, in a still air environment with $T_A=25^\circ C$. The value in any given application depends on the user's specific board design. The current rating is based on the $t \leq 10s$ thermal resistance rating.

B: The $R_{\theta JA}$ is the sum of the thermal impedance from junction to lead $R_{\theta JC}$ and lead to ambient.

Test Circuit:

(1)、EAS Test Circuit

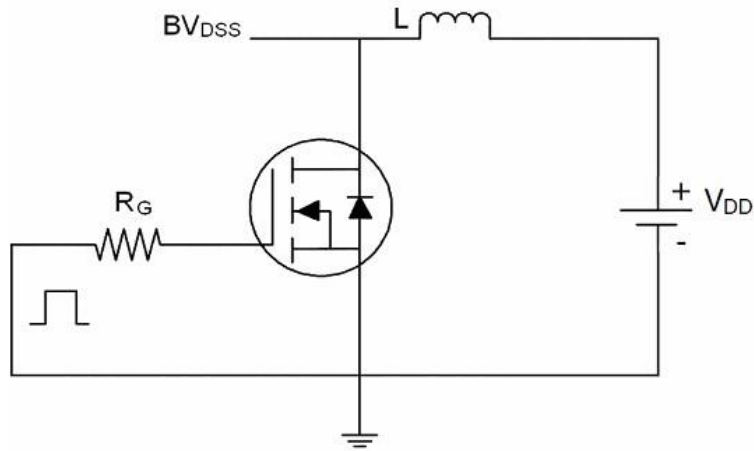

(2)、Gate Charge Test Circuit

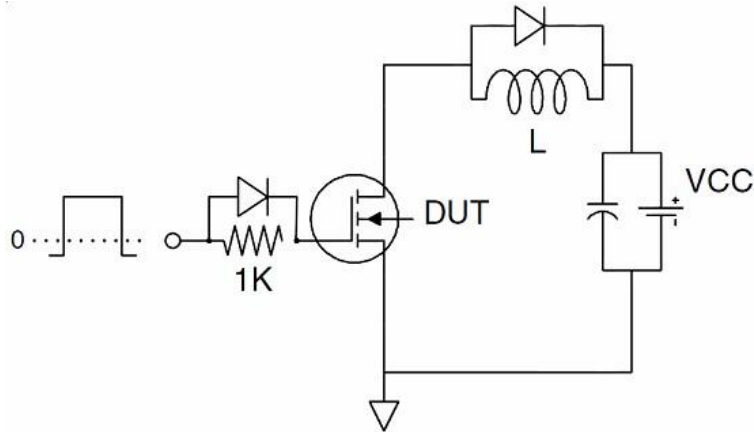

(3)、Switch Time Test Circuit

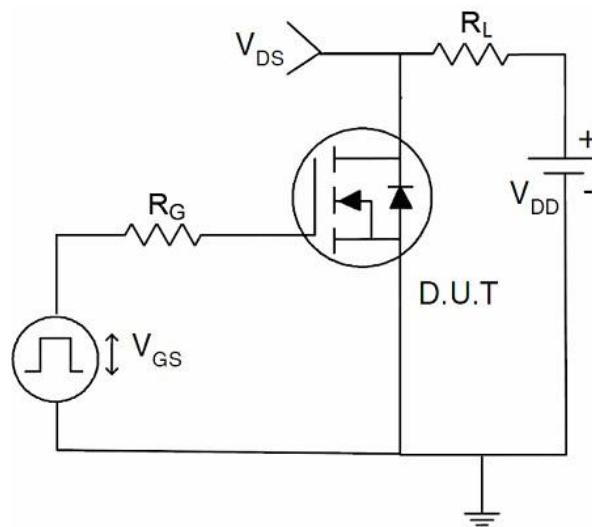

Package Information

- SOP-8

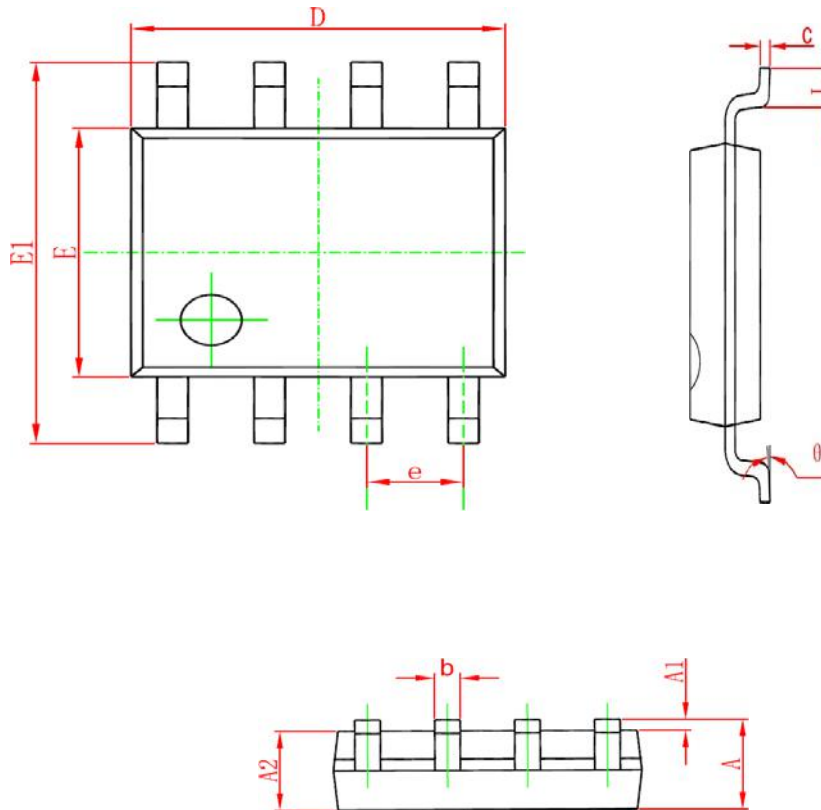

Symbol	Dimensions In Millimeters		Dimensions In Inches	
	Min	Max	Min	Max
A	1.350	1.750	0.053	0.069
A1	0.100	0.250	0.004	0.010
A2	1.350	1.550	0.053	0.061
b	0.330	0.510	0.013	0.020
c	0.170	0.250	0.006	0.010
D	4.700	5.100	0.185	0.200
E	3.800	4.000	0.150	0.157
E1	5.800	6.200	0.228	0.244
e	1.270 (BSC)		0.050 (BSC)	
L	0.400	1.270	0.016	0.050
θ	0°	8°	0°	8°

Recommended Minimum Pads

- SOP-8

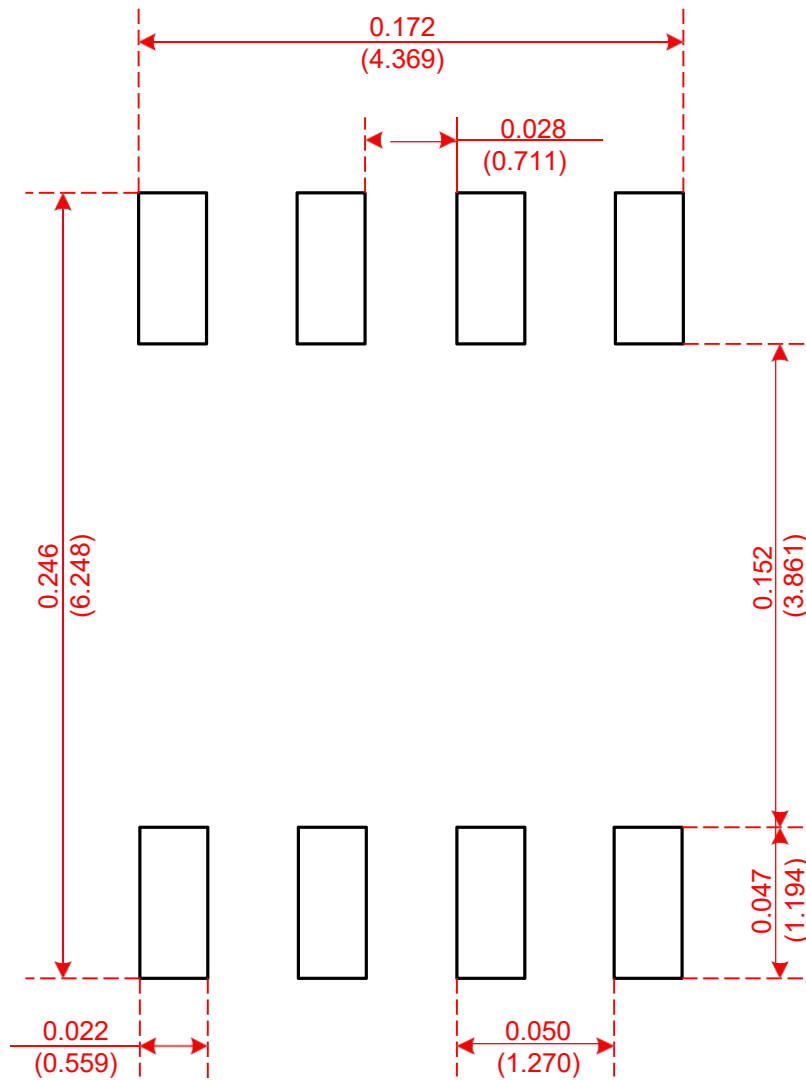

**Recommended Minimum Pads
Dimensions in Inches/(mm)**

Tape and Reel

- SOP-8

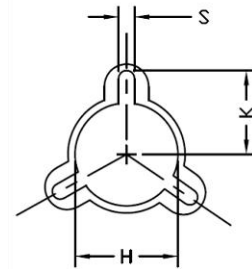
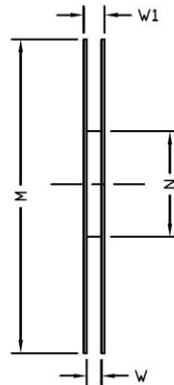
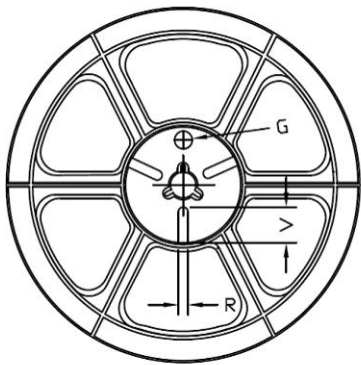
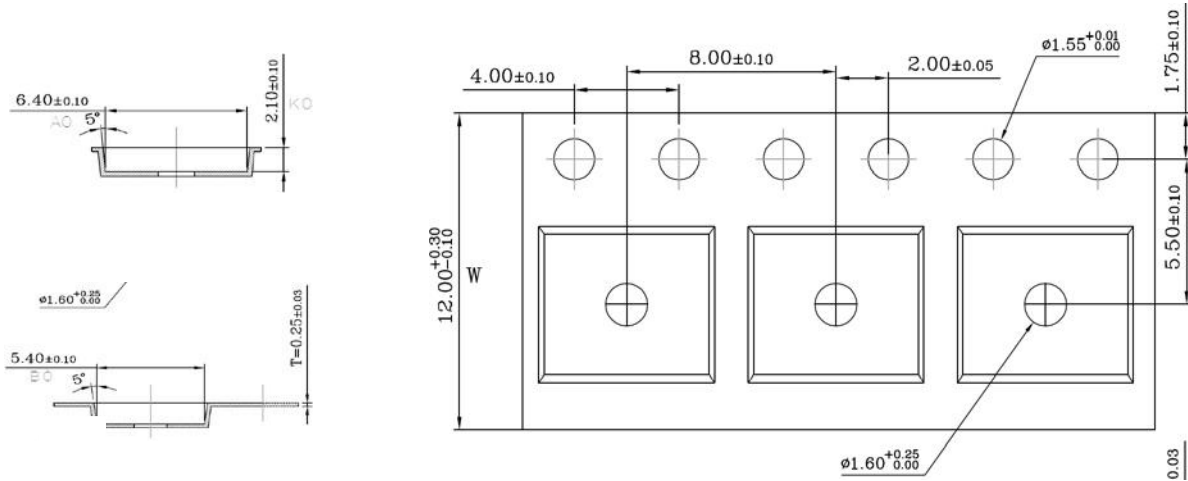

Tape Size	Reel Size	M	N	W	W1	H	K	S	G	R	V
12mm	Φ330	Φ330.00 ±0.50	Φ97.00 ±0.30	13.00 ±0.30	17.40 ±1.00	Φ13.00 ±0.5	10.6	2.00 ±0.50	—	—	—

Unit Per Reel:
4000pcs

