

30V Dual P-Channel Enhancement Mode MOSFET

Schematic diagram

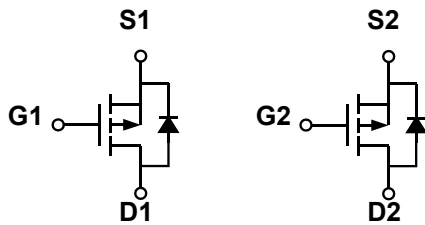

Marking and pin assignment

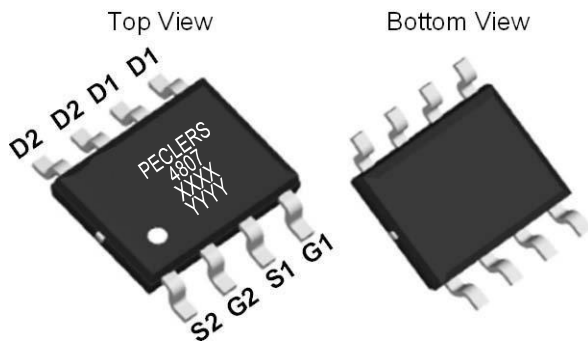

XXXX is the date code ,
YYYY is the Quality Code.



Description

The PECN4807 uses advanced trench technology to provide excellent $R_{DS(ON)}$, low gate charge and operation with gate voltages as low as 4.5V. This device is suitable for use as a load switch or in PWM applications.

General Features

- ◆ $V_{DS} = -30V$, $I_D = -12A$
 $R_{DS(ON)}(Typ.) = 13.5m\Omega @ V_{GS} = -4.5V$
 $R_{DS(ON)}(Typ.) = 9.5m\Omega @ V_{GS} = -10V$
- ◆ High power and current handling capability
- ◆ Lead free product is acquired
- ◆ Surface mount package

Application

- ◆ PWM applications
- ◆ Load switch

Package

- ◆ SOP-8

100% UIS TESTED!

100% ΔV_{ds} TESTED!

Ordering Information

Part Number	Storage Temperature	Package	Devices Per Reel
PECN4807SR	-55°C to +150°C	SOP-8	4000

Absolute Maximum Ratings (TA=25°C unless otherwise noted)

parameter	symbol	limit	unit	
Drain-source voltage	V_{DS}	-30	V	
Gate-source voltage	V_{GS}	±20	V	
Drain Current-Continuous (Silicon Limited)	I_D	$T_A = 25^\circ C$	-12	A
		$T_A = 75^\circ C$	-8	
Pulsed Drain Current (Package Limited)	I_{DM}	-44	A	
Maximum power dissipation	P_D	$T_A = 25^\circ C$	2	W
		$T_A = 75^\circ C$	1.3	
Operating junction Temperature range	T_j	-55—150	°C	

Electrical Characteristics (TA=25°C unless otherwise noted)

Parameter	Symbol	Condition	Min	Typ	Max	Unit
Static Characteristics						
Drain-source breakdown voltage	BV_{DSS}	$V_{GS}=0V, I_D=-250\mu A$	-30	-	-	V
Zero gate voltage drain current	I_{DSS}	$V_{DS}=-30V, V_{GS}=0V$	-	-	1	μA
		$T_J=85^\circ C$	-	-	30	
Gate Leakage Current	I_{GSS}	$V_{DS}=0V, V_{GS}=\pm 20V$	-	-	± 100	nA
Gate threshold voltage	$V_{GS(th)}$	$V_{DS}=V_{GS}, I_D=-250\mu A$	-1.0	-1.5	-2.5	V
Drain-source on-state resistance ¹	$R_{DS(ON)}$	$V_{GS}=-10V, I_D=-12A$	-	9.5	12	m Ω
		$V_{GS}=-4.5V, I_D=-8A$	-	13.5	16	
On Status Drain Current	$I_{D(ON)}$	$V_{DS}=-15V, V_{GS}=-10V$	11	-	-	A
Diode Characteristics						
Diode Forward Voltage	V_{SD}	$I_{SD}=-1A, V_{GS}=0V$	-	-0.8	-1.3	V
Diode Continuous Forward Current	I_S		-	-11	-	A
Reverse Recovery Time	t_{rr}	$I_F=-12A,$ $di/dt=-100A/\mu s$	-	24	-	ns
Reverse Recovery Charge	Q_{rr}		-	16	-	nC
Dynamic Characteristics						
Gate Resistance	R_G	$V_{GS}=0V, V_{DS}=0V, f=1MHz$	-	0.65	-	Ω
Input capacitance	C_{ISS}	$V_{GS}=0V, V_{DS}=-15V$ $f=1.0MHz$	-	2000	-	pF
Output capacitance	C_{OSS}		-	302	-	
Reverse transfer capacitance	C_{RSS}		-	227	-	
Turn-on delay time	$t_{D(ON)}$	$V_{GS}=-10V, V_{DD}=-30V,$ $R_L=3\Omega, I_D=1A, R_G=2.5\Omega$	-	9	-	ns
Turn-on Rise time	t_r		-	10	-	
Turn-off delay time	$t_{D(OFF)}$		-	50	-	
Turn-off Fall time	t_f		-	20	-	
Total gate charge	Q_g	$V_{GS}=-10V, I_D=-8A$ $V_{DS}=-15V$	-	31	-	nC
Gate-source charge	Q_{gs}		-	3	-	
Gate-drain charge	Q_{gd}		-	9	-	

Thermal Characteristics

Parameter	Symbol	Typ	Max	Unit
Maximum Junction-to-Ambient ^A	$\leq 10s$	33	40	$^\circ C/W$
Maximum Junction-to-Ambient ^A	Steady-State			
Maximum Junction-to-Lead ^B	Steady-State	16	24	

A: The value of R_{qJA} is measured with the device mounted on 1in 2 FR-4 board with 2oz. Copper, in a still air environment with $T_A=25^\circ C$. The value in any given application depends on the user's specific board design. The current rating is based on the $t \leq 10s$ thermal resistance rating.

B: The R_{qJA} is the sum of the thermal impedance from junction to lead R_{qJL} and lead to ambient.

Test Circuit:

1 、 EAS Test Circuit

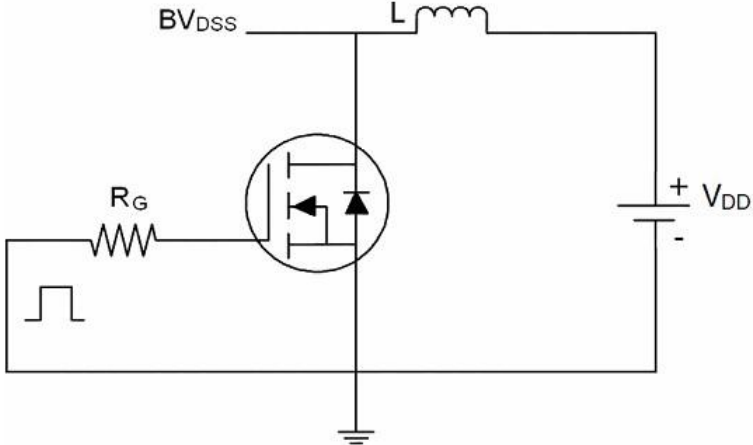

2 、 Gate Charge Test Circuit

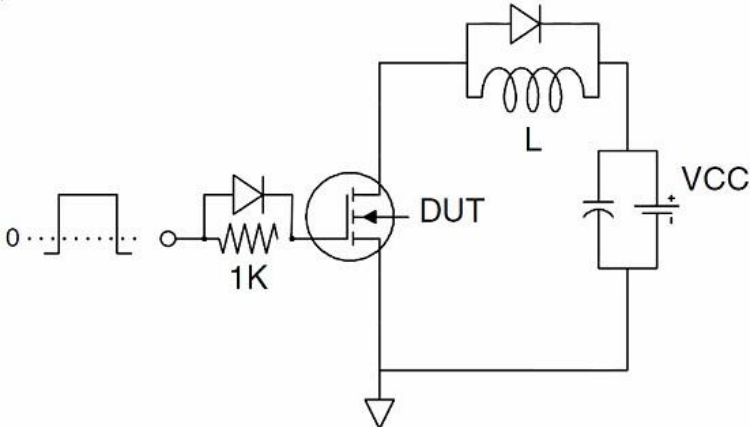

3 、 Switch Time Test Circuit

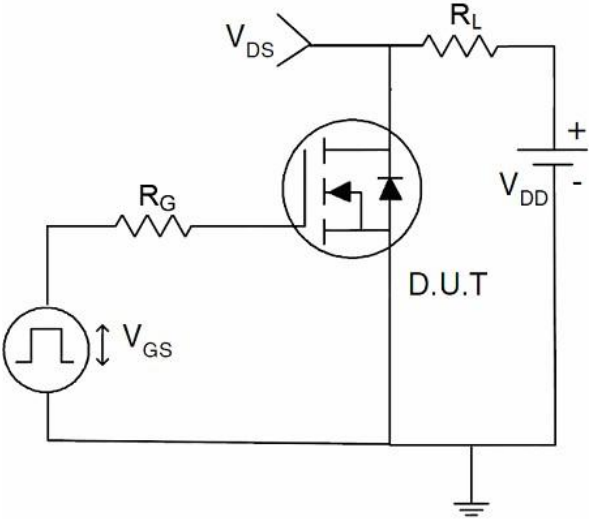

Package Information

- SOP-8

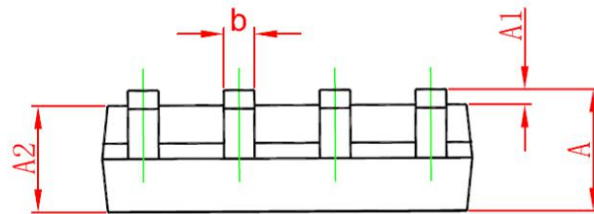
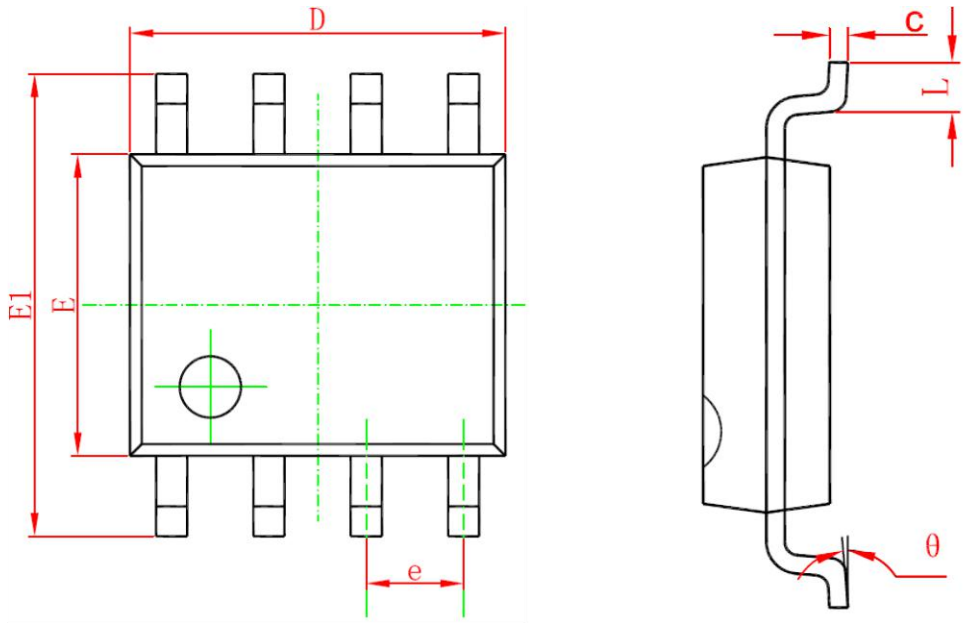

Symbol	Dimensions In Millimeters		Dimensions In Inches	
	Min	Max	Min	Max
A	1.350	1.750	0.053	0.069
A1	0.100	0.250	0.004	0.010
A2	1.350	1.550	0.053	0.061
b	0.330	0.510	0.013	0.020
c	0.170	0.250	0.006	0.010
D	4.700	5.100	0.185	0.200
E	3.800	4.000	0.150	0.157
E1	5.800	6.200	0.228	0.244
e	1.270 (BSC)		0.050 (BSC)	
L	0.400	1.270	0.016	0.050
θ	0°	8°	0°	8°

Recommended Minimum Pads

- SOP-8

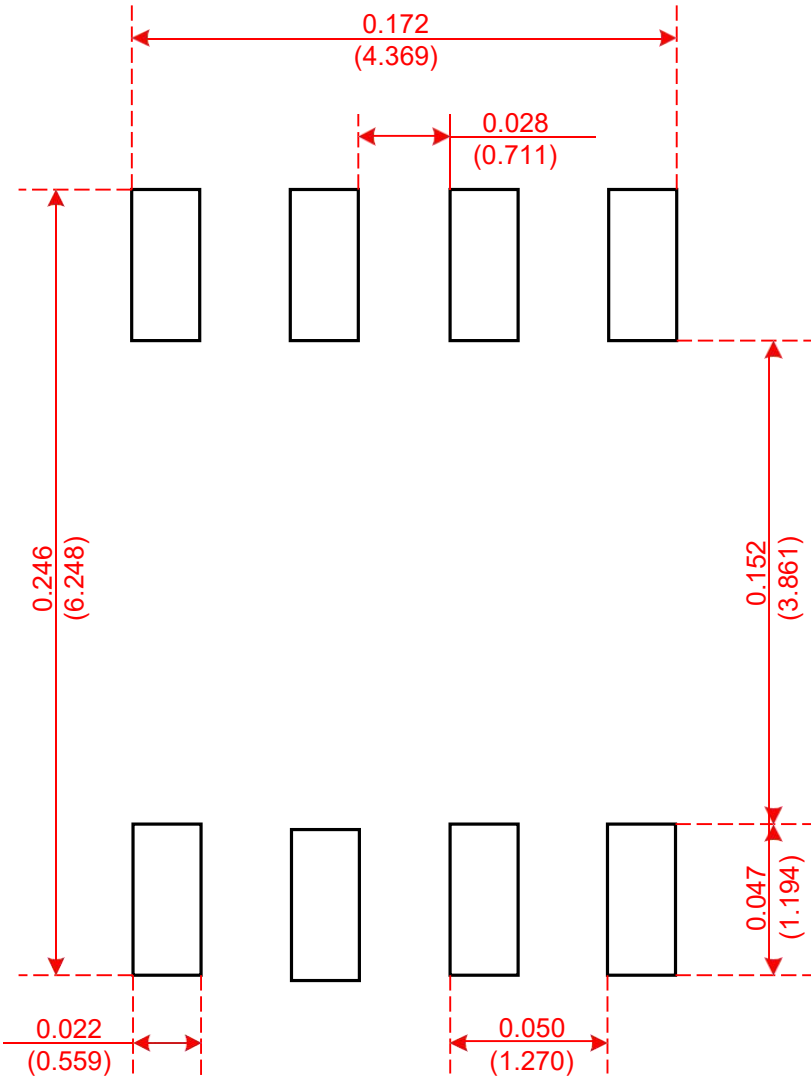

Recommended Minimum Pads
Dimensions in Inches/(mm)

Tape and Reel

- SOP-8

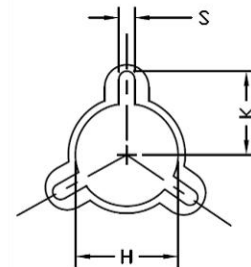
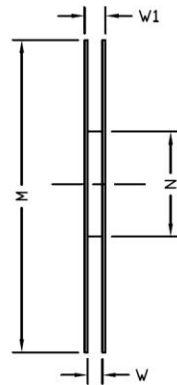
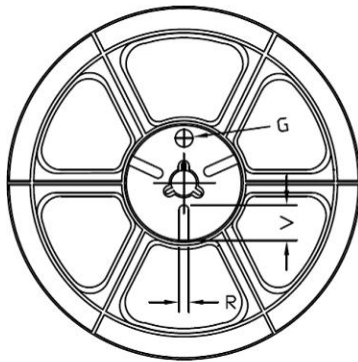
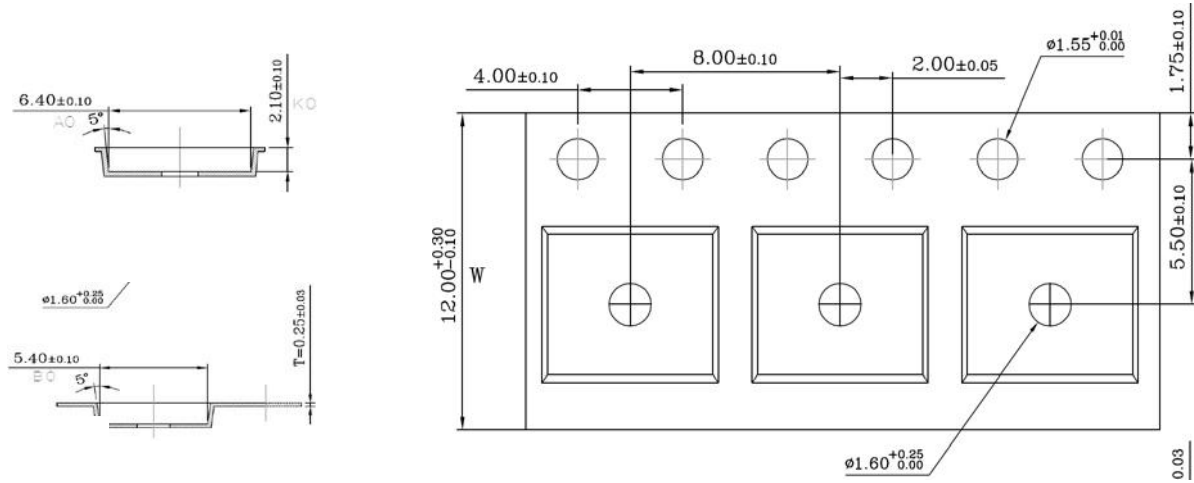

Tape Size	Reel Size	M	N	W	W1	H	K	S	G	R	V
12mm	Φ330	Φ330.00 ±0.50	Φ97.00 ±0.30	13.00 ±0.30	17.40 ±1.00	Φ13.00 ±0.5	10.6	2.00 ±0.50	—	—	—

Unit Per Reel:
4000pcs

