

### 30V N-Channel Enhancement Mode MOSFET

#### Schematic diagram

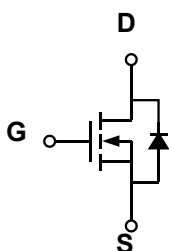

#### Marking and pin assignment

SOT-23-3L  
(TOP VIEW)

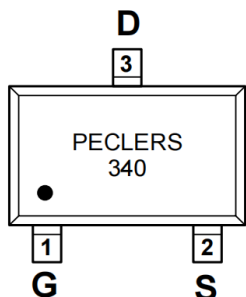

#### Description

The PECN3400AMR uses advanced trench technology to provide excellent  $R_{DS(ON)}$ , low gate charge and high density cell Design for ultra low on-resistance. This device is suitable for use as a load switch or in PWM applications.

#### General Features

- ◆  $V_{DS} = 30V$ ,  $I_D = 7A$   
 $R_{DS(ON)}(Typ.) = 23m\Omega$  @  $V_{GS} = 2.5V$   
 $R_{DS(ON)}(Typ.) = 17m\Omega$  @  $V_{GS} = 4.5V$
- ◆ High power and current handling capability
- ◆ Lead free product is acquired
- ◆ Surface mount package

#### Application

- ◆ PWM applications
- ◆ Load switch

#### Package

- ◆ SOT-23-3L



#### Ordering Information

Part Number	Storage Temperature	Package	Devices Per Reel
PECN3400AMR	-55°C to +150°C	SOT-23-3L	3000

#### Absolute Maximum Ratings (TA=25°C unless otherwise noted)

parameter	symbol	limit	unit	
Drain-source voltage	$V_{DS}$	30	V	
Gate-source voltage	$V_{GS}$	±12	V	
Continuous Drain Current	$I_D$	$T_C = 25^\circ C$	7	A
		$T_C = 70^\circ C$	6	
Pulsed Drain Current <sup>C</sup>	$I_{DP}$	28	A	
power dissipation <sup>B</sup>	$P_D$	$T_C = 25^\circ C$	1.4	W
		$T_C = 70^\circ C$	0.9	
Junction and Storage Temperature Range	$T_J, T_{SGT}$	-55—150	°C	

### Electrical Characteristics (TA=25°C unless otherwise noted)

Parameter	Symbol	Condition	Min	Typ	Max	Unit
<b>OFF Characteristics</b>						
Drain-source breakdown voltage	$BV_{DSS}$	$V_{GS}=0V, I_D=250\mu A$	30	-	-	V
Zero gate voltage drain current	$I_{DSS}$	$V_{DS}=30V, V_{GS}=0V$	-	-	1	$\mu A$
Gate-body leakage	$I_{GSS}$	$V_{DS}=0V, V_{GS}=\pm 12V$	-	-	$\pm 100$	nA
<b>ON Characteristics</b>						
Gate threshold voltage	$V_{GS(th)}$	$V_{DS}=V_{GS}, I_D=250\mu A$	0.5	0.9	1.3	V
Drain-source on-state resistance	$R_{DS(ON)}$	$V_{GS}=4.5V, I_D=7A$	-	17	23	m $\Omega$
		$V_{GS}=2.5V, I_D=7A$		23.4	30	
Forward transconductance	gfs	$V_{GS}=5V, I_D=7A$	-	33	-	S
<b>Dynamic Characteristics</b>						
Input capacitance	$C_{ISS}$	$V_{DS}=15V, V_{GS}=0V$ $f=1.0MHz$	-	813	-	pF
Output capacitance	$C_{OSS}$		-	98	-	
Reverse transfer capacitance	$C_{RSS}$		-	56	-	
<b>Switching Characteristics</b>						
Turn-on delay time	$t_{D(ON)}$	$V_{DS}=15V$ $V_{GS}=10V$ $R_L=2.6\ ohm$ $R_{GEN}=3ohm$	-	3	-	ns
Rise time	tr		-	3	-	
Turn-off delay time	$t_{D(OFF)}$		-	26	-	
Fall time	tf		-	3.6	-	
Total gate charge	Qg	$V_{DS}=15V, I_D=5.8A$ $V_{GS}=4.5V$	-	8	12	nC
Gate-source charge	Qgs		-	1.2	-	
Gate-drain charge	Qgd		-	2.6	-	
<b>DRAIN-SOURCE DIODE CHARACTERISTICS</b>						
Diode forward voltage	$V_{SD}$	$V_{GS}=0V, I_S=1A$	-	0.76	1.16	V

### Thermal Characteristics

Parameter	Symbol	Typ.	Max.	Unit
Maximum Junction-to-Ambient <sup>A</sup>	$t \leq 10s$	70	90	$^{\circ}C/W$
Maximum Junction-to-Ambient <sup>A D</sup>	Steady-State	100	125	
Maximum Junction-to-Lead	Steady-State	62	80	

A. The value of  $R_{\theta JA}$  is measured with the device mounted on 1in<sup>2</sup> FR-4 board with 2oz. Copper, in a still air environment with  $T_A = 25^{\circ}C$ . The value in any given application depends on the user's specific board design.

B. The power dissipation PD is based on  $T_{J(MAX)}=150^{\circ}C$ , using  $\leq 10s$  junction-to-ambient thermal resistance.

C. Repetitive rating, pulse width limited by junction temperature  $T_{J(MAX)}=150^{\circ}C$ . Ratings are based on low frequency and duty

### Package Information

- SOT-23-3L

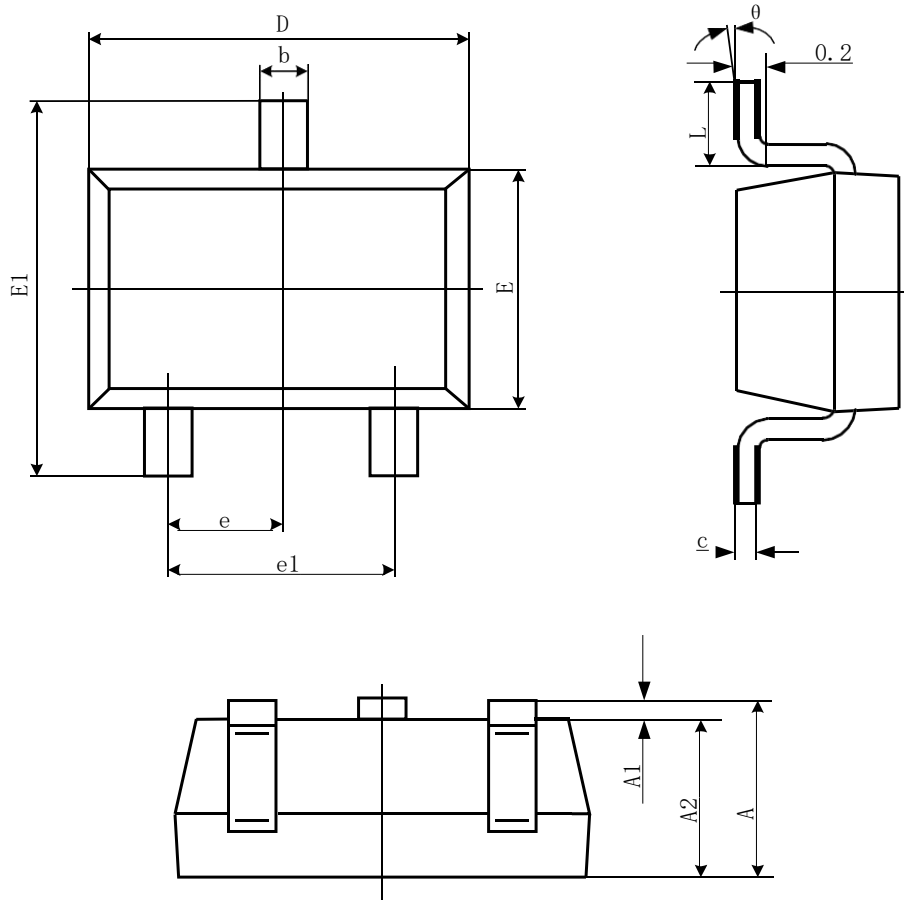

Symbol	Dimensions In Millimeters		Dimensions In Inches	
	Min	Max	Min	Max
A	1.050	1.250	0.041	0.049
A1	0.000	0.100	0.000	0.004
A2	1.050	1.150	0.041	0.045
b	0.300	0.500	0.012	0.020
c	0.100	0.200	0.004	0.008
D	2.820	3.020	0.111	0.119
E	1.500	1.700	0.059	0.067
E1	2.650	2.950	0.104	0.116
e	0.950(BSC)		0.037(BSC)	
e1	1.800	2.000	0.071	0.079
L	0.300	0.600	0.012	0.024
θ	0°	8°	0°	8°